



• DATASHEET

BIKE MAINTENANCE STATION

MAXIMA



MAXIMA



TECHNICAL SPECIFICATIONS

MAXIMA

This maintenance and pumping station is easy to use and compatible with bikes of all types. Its structure is light and robust. The bike is lifted and held securely off the ground by placing the saddle on the support arm. This way the bike is easily and fully accessible for maintenance, which is carried out using the tools attached to the station by means of steel cables. The tools are of excellent quality and each serve a specific purpose. The pump and pressure gauge allow you to measure tyre pressure accurately. The station is equipped with a high-quality pump and a glycerine-filled pressure gauge that does not allow condensation to form, making it so that pressure can be read clearly..

PUMP

It is made entirely by GREEN GARAGE BIKE and is easy to use. It is compatible with all types of valves that are to be found on the market (8 bar max).

MATERIALS USED

Anticorodal aluminium structure. Various stainless-steel bolts.

STANDARD (MATTE) COLOURS

Ral 5024 (Air force blue)  Ral 7030 (Urban)  Ral 6021 (Olive)  Ral 6018 (Green) 

HOW TO INSTALL IT

The base of the station has 4 holes $\varnothing 11$ that allow it to be fixed to the ground, using the fixing caps that have been provided. Anti-theft caps are available on request. For safety reasons, we recommend that the station be secured before use.

MAINTENANCE

Despite its exposure to atmospheric conditions, the station does not require any extraordinary maintenance work, due to the fact that it is made of aluminium and steel components. We recommend covering it in the event that it is not used in winter. Pump: we recommend lubricating the stem from time to time.

WARRANTY

There is a 2-year warranty on all of the station's structural parts (including the pump), with the exception of parts prone to wear and tear (i.e. gaskets, rings etc.). Spare parts are available for all station components. Ask for prices and availability. The warranty does not cover any damage caused by individuals or vandalism. THE WARRANTY IS EX-WORKS GREEN GARAGE BIKE.

OVERALL SIZE AND WEIGHT

Support arm 29.5 cm - Height 150.6 cm - Width 44 cm - Depth 30 cm - Weight 22 kg

TOOLS

1 Phillips-head screwdriver - 1 flat-head screwdriver - 1 0/22 mm universal spanner - 1 pair of tyre levers - 1 15 mm spanner - 1 13 mm spanner - 1 2.5/10 mm multi-tool Allen key kit

CUSTOMISED GRAPHICS

GREEN GARAGE BIKE offers the possibility of customising the station with the customer's graphics. Send us a vector file and we will provide you with a quotation for the customisation work.

SIZE

MAXIMA

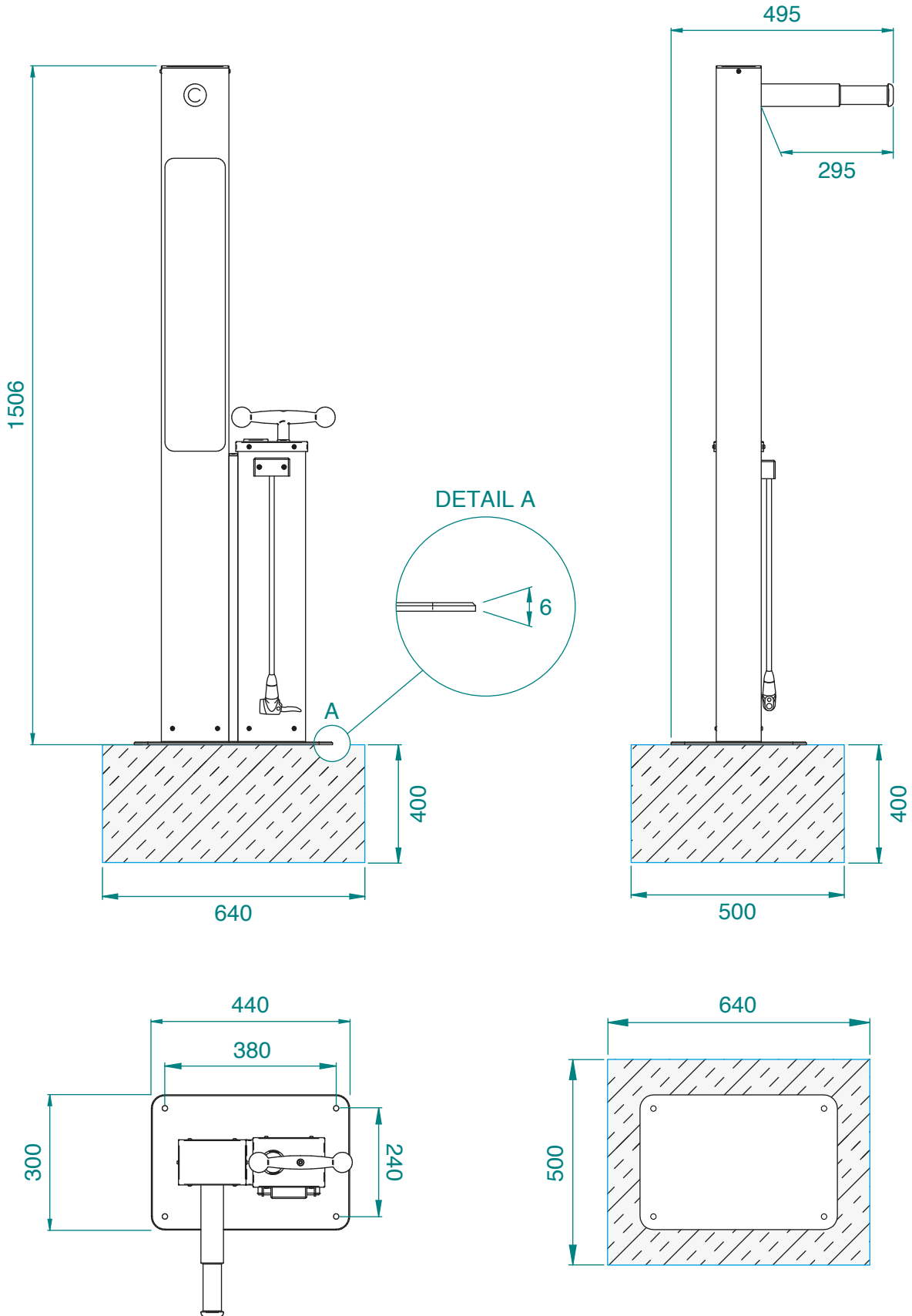

CUSTOM GRAPHICS SIZE

MAXIMA

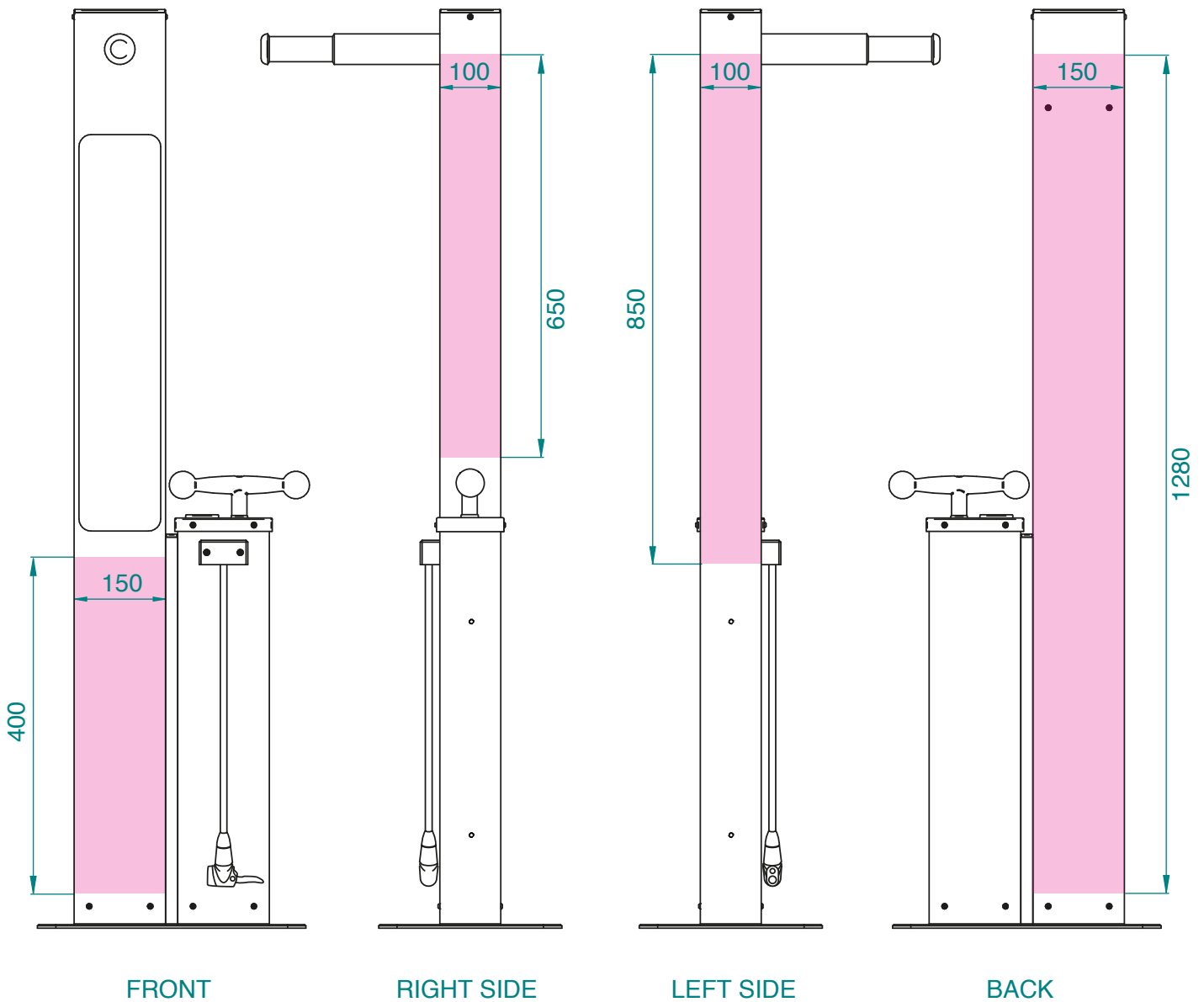

GRAPHICS SIZE

